

PLCV7.1-1500

with indicative structure for ceiling box and ceiling cover

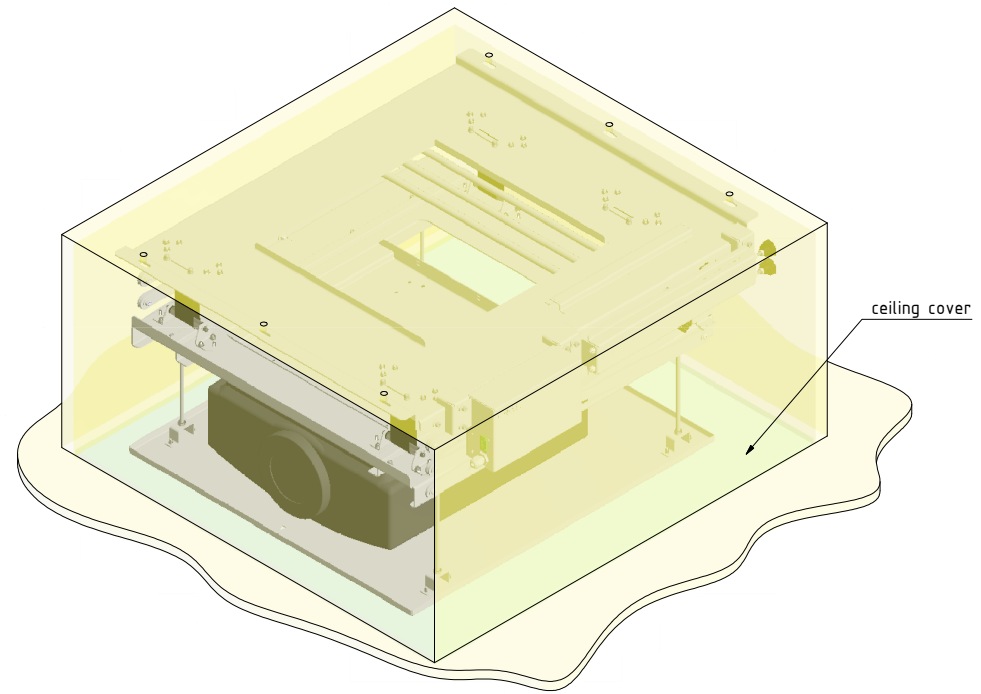
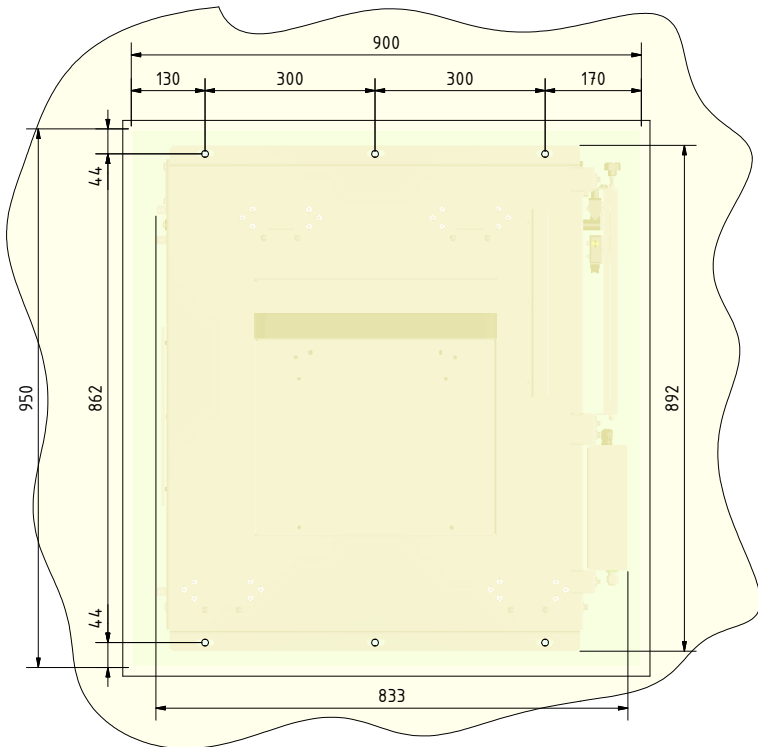
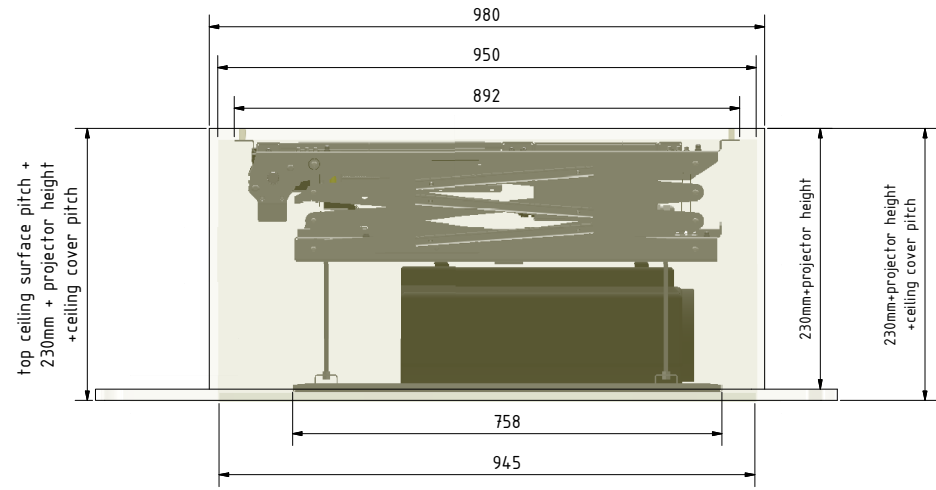
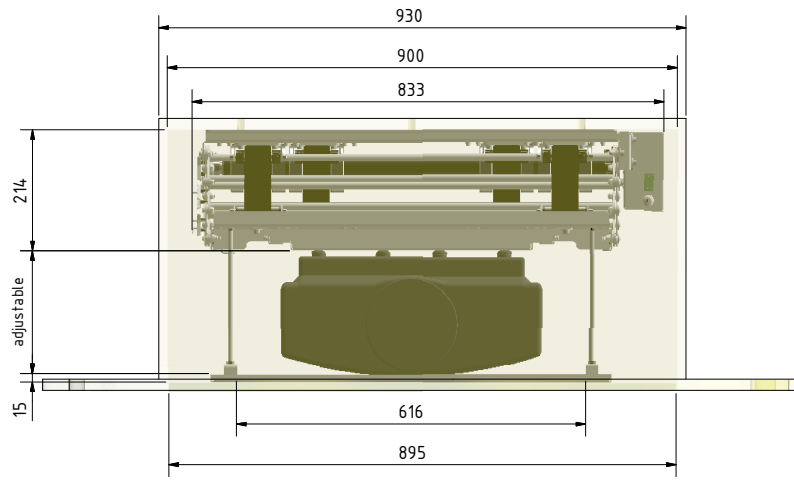

CATEGORY	PROJECTOR CEILING LIFTS	DRAWING TYPE		
MODEL	PLCV7.1-1500	DRAFT	FINAL	
FEATURES	MAXIMUM LOAD CAPACITY 50kg, NET VERTICAL MOTION 1500mm, ADJUSTABLE PROJECTION POSITION BELOW 500mm, ADJUSTABLE UP-CLOSED POSITION, FIXED SERVICE POSITION AT 1500mm, DETACHABLE DRY CONTACTS CONTROL BOX (CONNECTION CABLE MAX. LENGTH 1,5m)		x	
COLOUR	BLACK RAL9005	DIMENSIONS TOLERANCE		
DRAWING No	12052019-SK	APPROVED BY:	+/- 0,5%	
ALL RIGHTS STRICTLY RESERVED. REPRODUCTION OR ISSUE TO THIRD PARTIES IN ANY FORM WHATSOEVER, IS NOT PERMITTED WITHOUT WRITTEN AUTHORITY FROM UNITECH SYSTEMS.				