

# PLCV5.3 +2XD-CLOSED

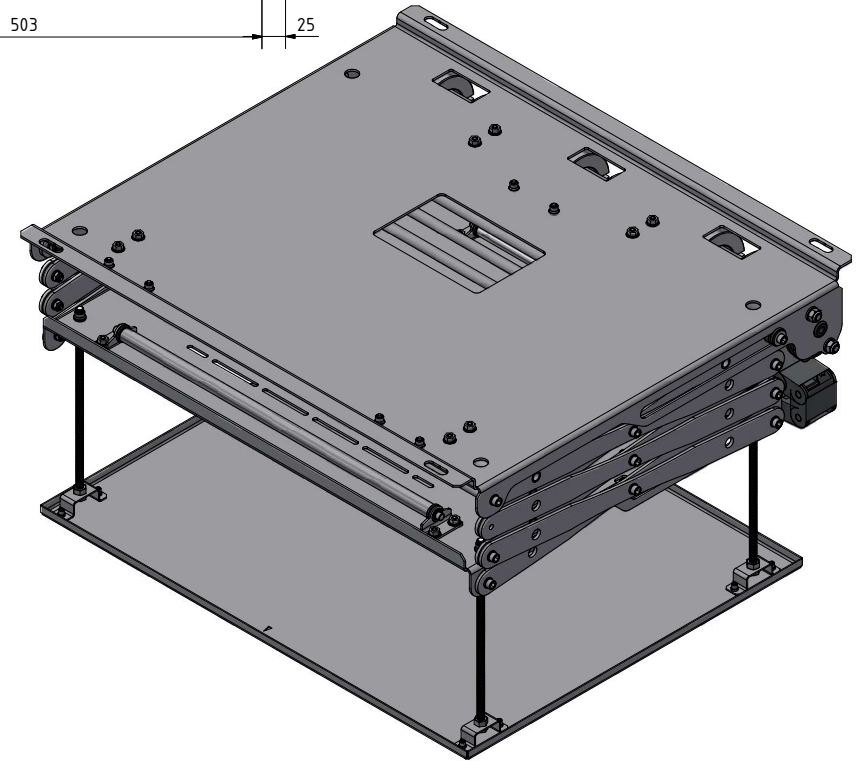

CATEGORY	PROJECTOR CEILING LIFT	DRAWING TYPE	
MODEL	PLCV5.3 +2XD	DRAFT	FINAL
FEATURE	NET VERTICAL DROP 945mm, MAXIMUM LOAD CAPACITY 20kg (±projector weight + ceiling cover weight)	x	
COLOUR	POWDER COATING RAL9005(BLACK BUFF)	DIMENSIONS TOLERANCE	
DRAWING No	V03-260126-DL	+/-0,5%	
APPROVED BY:			

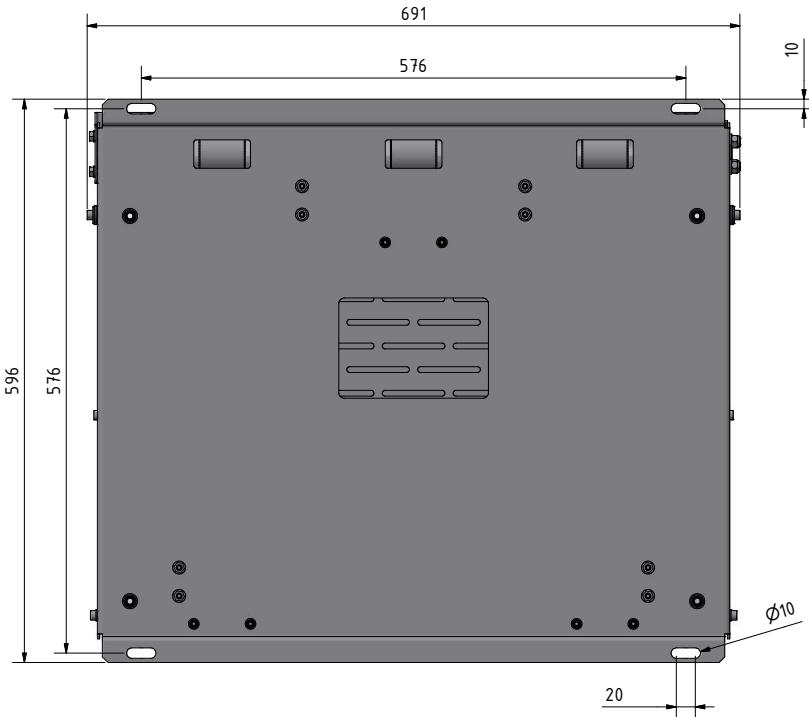
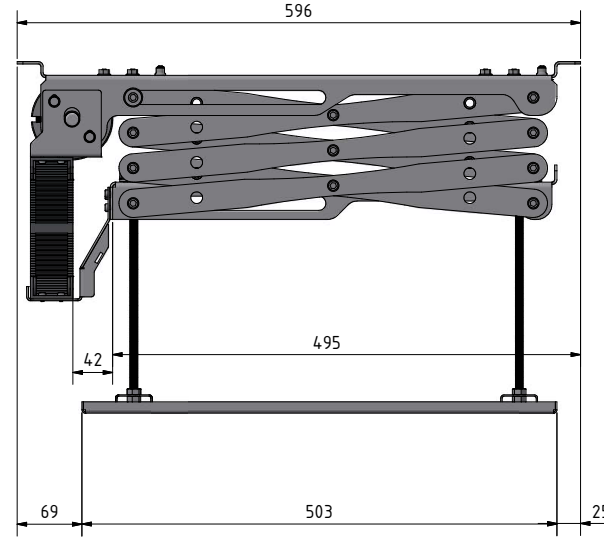
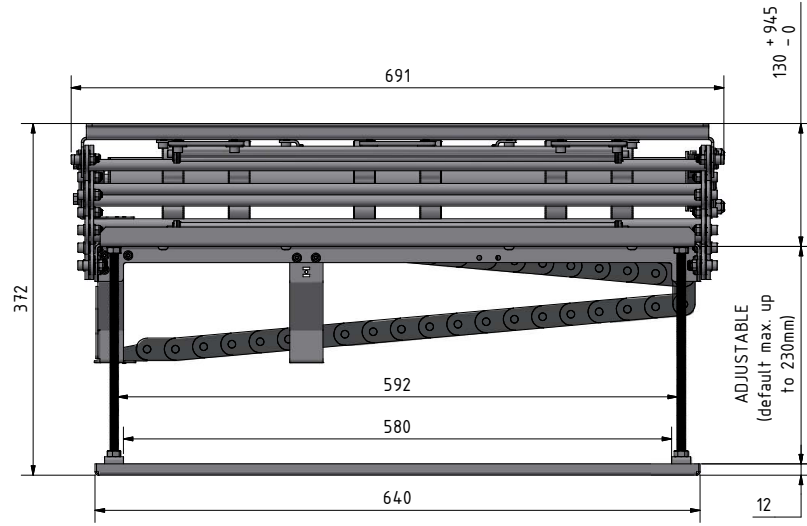